

Phoenix

Assembly Manual

AVIATION DESIGN

ZI le chenet, 91490 Milly La Foret, FRANCE

Tel : 33 1 64 98 93 93

Fax : 33 1 64 98 93 88

E-mail : aviation.design@wanadoo.fr

www.adjets.com

Version 01/01/2006

INTRODUCTION

Phoenix is our new jet trainer. It is fully composite, delivered assembled and painted.

It is designed for jet beginner with following objective :

- Very easy to fly.
- Short take off and landing due to big airfoil thickness (13%), large flaps and low wing loading
- Very fast assembly
- Easy access to engine (top engine, no hatch, no exhaust pipe)
- Easy access to fuel tank , ECU and radio with a large fuselage hatch
- Easy radio installation with big fuselage hatch and servo cover supplied

The **Phoenix** is fully molded in composite material.

The model comes to you finished, fully molded in composite material and painted in mold. All bulkheads are glued. All control surfaces are hinged. No gluing are required. This model has plug in wings, stabs and fin booms for an easier transport.

All necessary hardware are included in the parcel

Assembly require only few hours to fit engine and radio.

Phoenix ARF model includes :

- High quality epoxy-glass fuselage painted.
- All plywood and wood parts premounted.
- Fully molded wings with winglets, stabs and fin booms painted
- High tensile aluminum wing joining tube.
- Access hatch requiring no additional framework.
- All hardware (screws, servo cover, ...)
- Instructions in English with pics.

Parts required to complete the kit :

- 2 liters kevlar fuel cell
- Deluxe retractable landing gear with special CNC oleo legs and wheels set on bearing + brakes
- Clear canopy



DISCLAIMER

AVIATION DESIGN assumes no liability for the operation and use of these products.

The owner and operator of these products should have the necessary experience and exercise common sense. Said owner and operator must have a valid Model Airplane licence and insurance as required.

Assembly Instructions

Installation of the radio equipment

Components need:

Elevator: 1 servo 5 kg torque

Rudder: 2 mini servos 3 kg torque (Hitec HS-225)

Ailerons: 2 mini servos 3 kg to 4 kg torque (Hitec HS-225MG)

Flaps: 2 mini servos 4 kg torque (Hitec HS-225MG)

Steering nose wheels: 1 servo 3 kg torque

Receiver and switch

Fuselage hatch:



If necessary, sand a little bit the rear plywood frame so that the fuel tank fit in without problem.

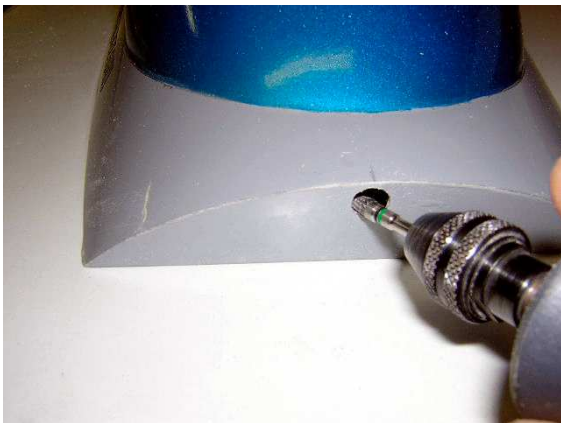

Make a 6 mm hole in front of the fuselage hatch for the wood pin.

Glue the wood pin with CA in the hatch

Drill the corresponding hole in the front fuselage

Cut a slot and make a 3 mm hole in the back of the hatch for the hatch latch



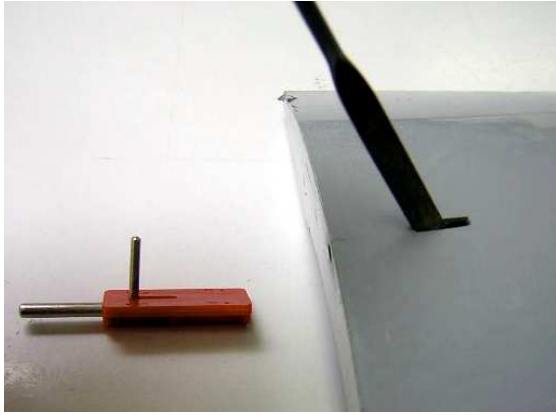

Glue the hatch latch with CA. Take care to not glue the metallic part
Fit the hatch on the fuselage and draw the corresponding hole
Drill the 3 mm hole in the fuselage

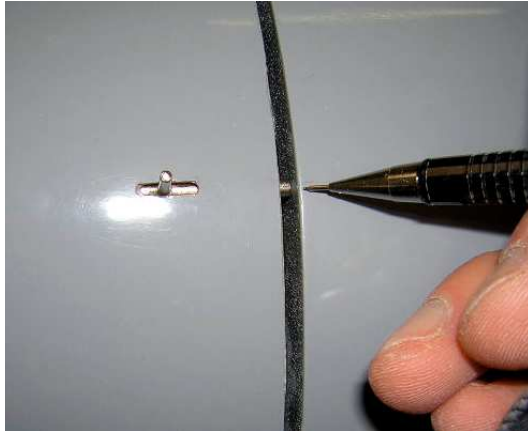

Gear :

Please, use only the oleo legs supply by Aviation Design.

If you use standard oleo, you will have to modify the gear position and gear door position

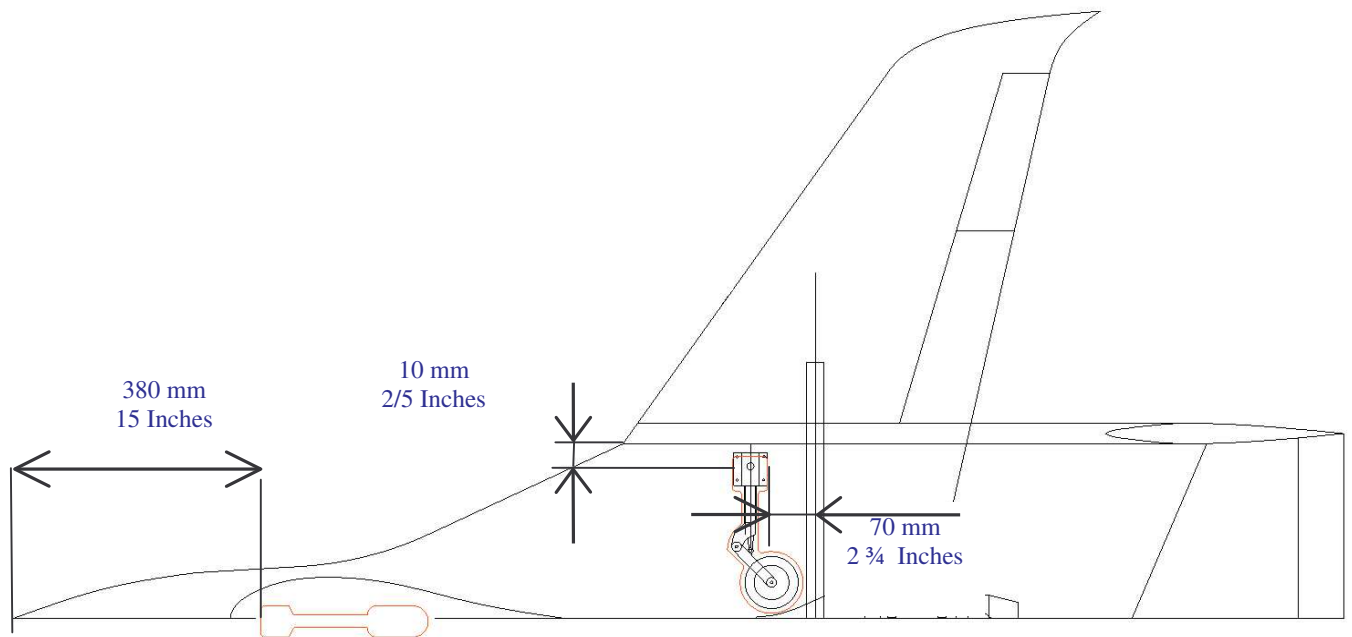

Draw the fuselage axis under the fuselage with a ruler

Draw the front gear door location and main gear door location according to the drawing and template

Cut all gear doors using a fine diamond disc and dremel tool

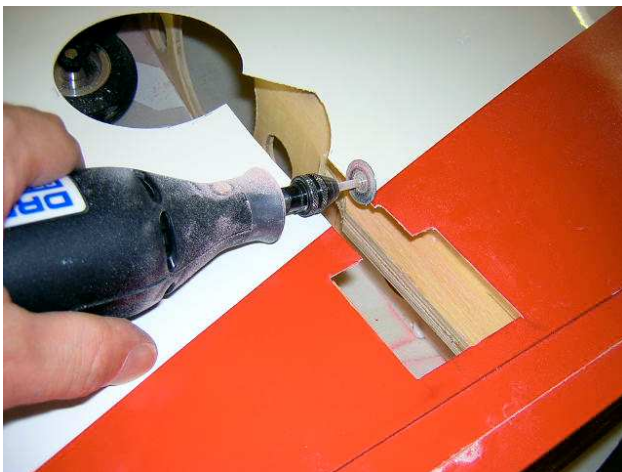

Fit the main gear on the plywood mount a drill four 2 mm hole
Screw each gear with four 3x20 mm parker screws



Fit the front gear on the plywood mount a drill 4 x 2 mm hole
Screw the front gear with four 3x20 mm parker screws



Screw the steering servo inverted on the plywood frame

Connect servo to steering arm with 2 mm link + steel wire

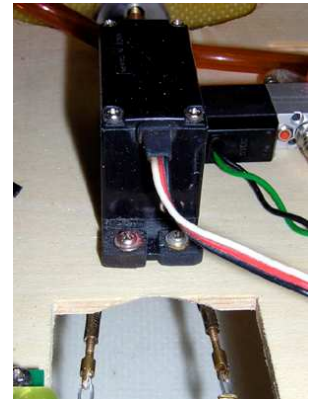

Stab servo :

Increase the hole for the servo location in the stab with a permagrit rotating tool
Screw the servo in the servo cover (you can also glue it with silicon glue for more security)



Put in place the servo cover on the stab
Drill 4 x 1 mm hole in the stab for the screws
Make a 10 mm hole in on side of the stab for the servo connector



Cut a slot in the control surface for the fiber control horn
Glue with fast epoxy the control horn
Connect two 3 mm link with M3 threaded rod
Screw the servo cover with the 4 parker screws
Connect the servo with the control horn
Apply thread lock.



Aileron and flaps servos :

Process as the stab servo :

Increase the hole for the servo location in the wings with a permagrit rotating tool for the aileron and flaps

Screw the servo in the servo cover (you can also glue it with silicon glue for more security)

Put in place the servo cover on the wings

Drill 4 x 1 mm hole in the wings for the screws



Cut a slot in the control surface for the fiber control horn

Glue with fast epoxy the control horn

Connect two 2 mm link with M2 threaded rod

Screw the servo cover with the 4 parker screws

Connect the servo with the control horn

Apply thread lock.

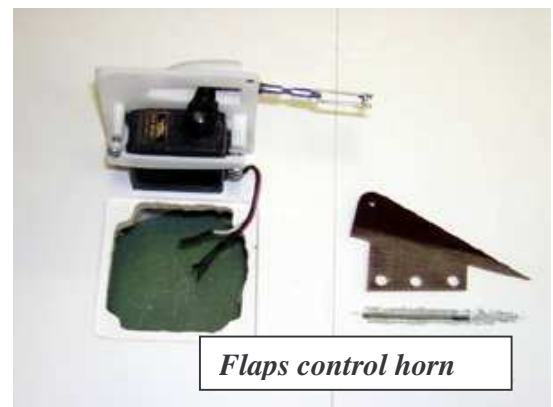

Make a 5 mm hole in the wing root for the servo electric wire

Don't make the hole too big so that the connector can't fall in the wing

Sold electric wire for the flaps and aileron



Rudder servos :

Process as the stab servo :

Increase the hole for the servo location in the booms with a permagrit rotating tool for the rudder

Screw the servo in the servo cover (you can also glue it with silicon glue for more security)

Put in place the servo cover on the boom

Drill 4 x 1 mm hole in the wings for the screws

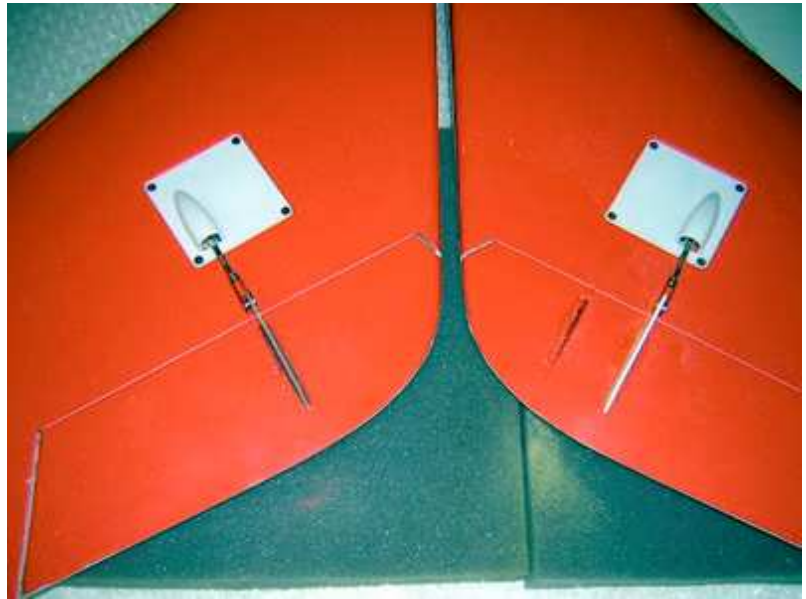

Cut a slot in the control surface for the fiber control horn

Glue with fast epoxy the control horn

Connect two 2 mm link with M2 threaded rod

Screw the servo cover with the 4 parker screws

Connect the servo with the control horn
Apply thread lock.



Make a 20 mm hole in the boom in front of the hole of the wing root for the servo electric wire.

Drill this hole on both side of each boom.

Sold electric wire for the rudder

Make a 5 mm hole in the boom in front of stab root for the elevator electric wire

Don't make the hole too big so that the conector can't fall in the boom.

Sold electric wire for the elevator.

Secure the wings :

Fit the wing joiner tube through the fuselage.
Install the left and right booms .
Take care to put it at the center (same length left and right (about 220 mm)).
Install the left and right wings.

Make a 2.5 mm hole at 30 mm from the wing root through the wing and aluminium tube to secure the wings

Threated the wing tube and wing at M3 mm and secure wings with a M3x25 screw



Secure also the tube in the fuselage.

Make a 2.5 mm hole in the center of the fuselage from the gear door. Drill the hole through the plywood frame and aluminium tube to secure the tube.

Screw a 3 x 16 mm parker screw through the plywood and aluminium tube, so the tube will not move during assembling and desassembling.

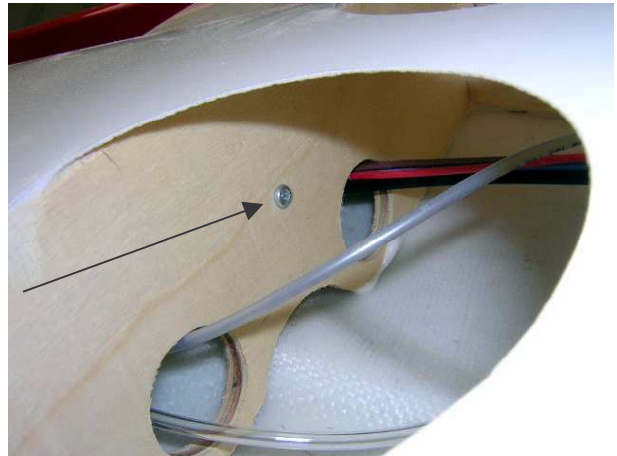

Secure the horizontal stabilisator :

Install the stab between the 2 booms.
Secure the stab with two M6x40 nylon screws

Fuel tank

Connect the fuel tank to the clunk as the photo.
Check that there is no leak before to fit it in fuselage.

Drill a 3 mm hole in the bottom of the fuselage for the fuel vent

The fuel tank is connected to the small catch tank (200 cc) or UAT catch tank to be sure that there is no bubble in the fuel line.

The tubing from the main tank to the catch tank and to the catch tank to the fuel pump must be gasoline tubing (no silicone tubing). Also for the air vent tube.

The catch tank is glue with double face tape on the bottom of the fuselage close to the main tank or with rubber band to the main tank.

Hold the fuel tank with rubber bands or silicon glue

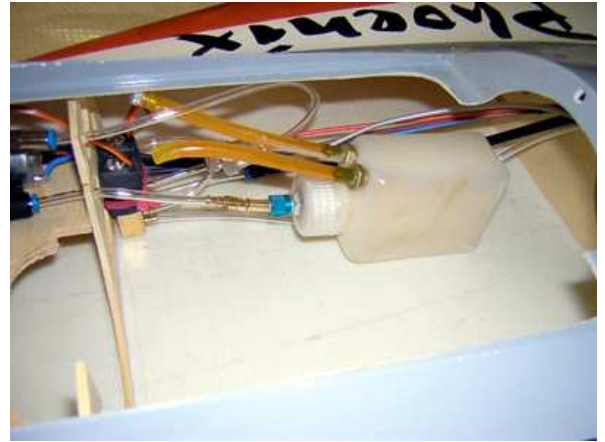
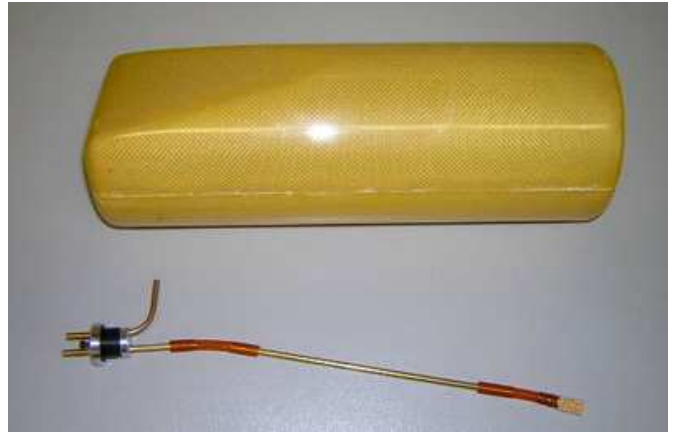

Filling the fuel tanks :

Connect your pump and fill the system in direction of the tank. It will first fill the catch tank and after the main tank.
The main tank will be full when fuel come from the air

vent tube.

When tanks are full, close the filling tubing.

Do not close the air vent tube after.

The system is ready for starting.

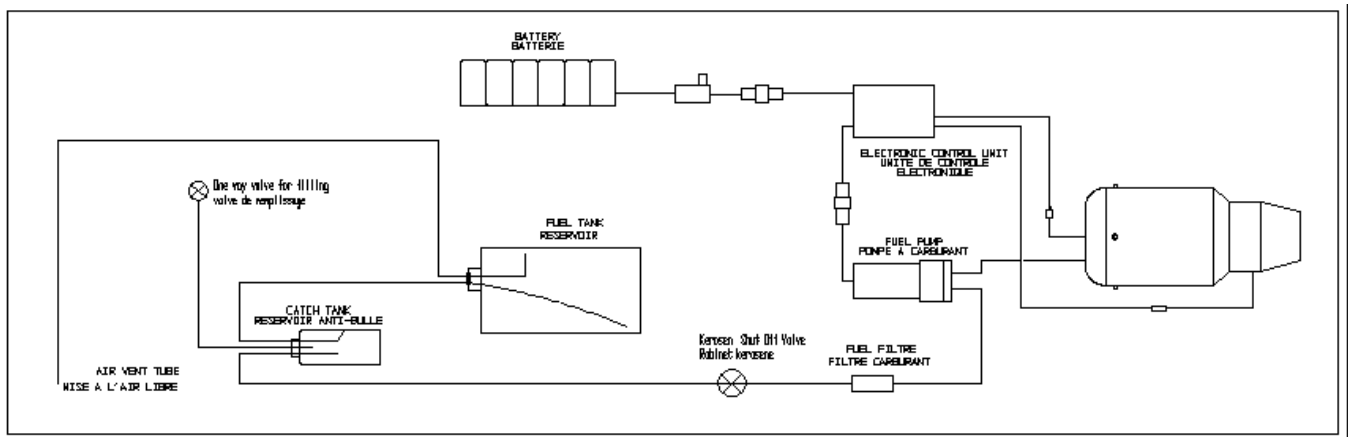
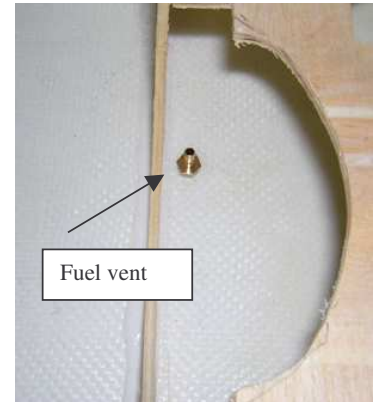

Engine installation :

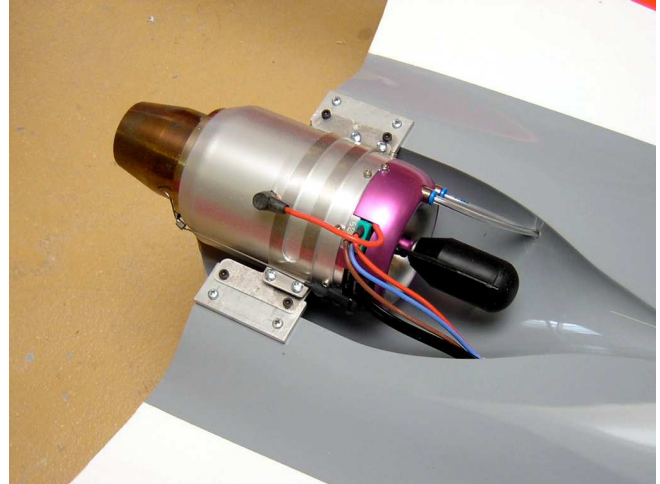

The engine must be screw with 4 times 3x20 mm parker screw to the rear position.
A plywood reinforcement is already glued inside the fuselage

For small engine like P60, engine mountings are not large enough to be screw on the fuselage.
In this case make some extension pad in 3 mm aluminium

Make all necessary hole in the fuselage for electric wire and fuel tubing in front of the engine

ECU installation :

Fit the ECU in one side of the plane.

Fit the fuel pump and valves just rear to the ECU and hold them with T rap.

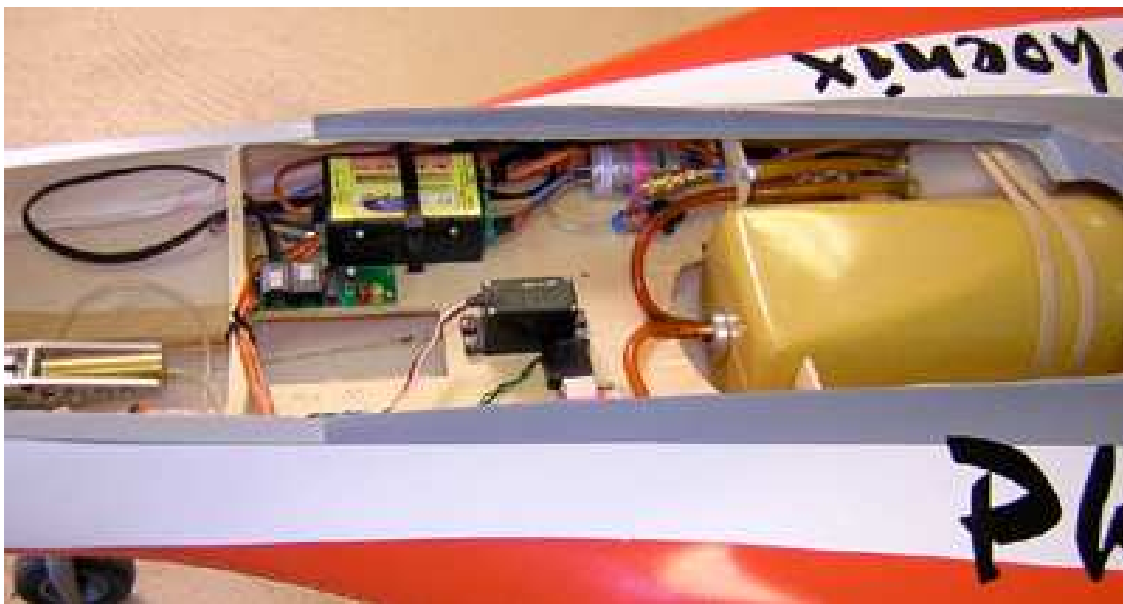

Radio installation :

Fit the radio in the nose section with batterie.
Adjust batterie position to have to correct CG position.
Don't put the received and aerial antennae too close the the ECU

Retract valve and brake valve can be fitted as the pics

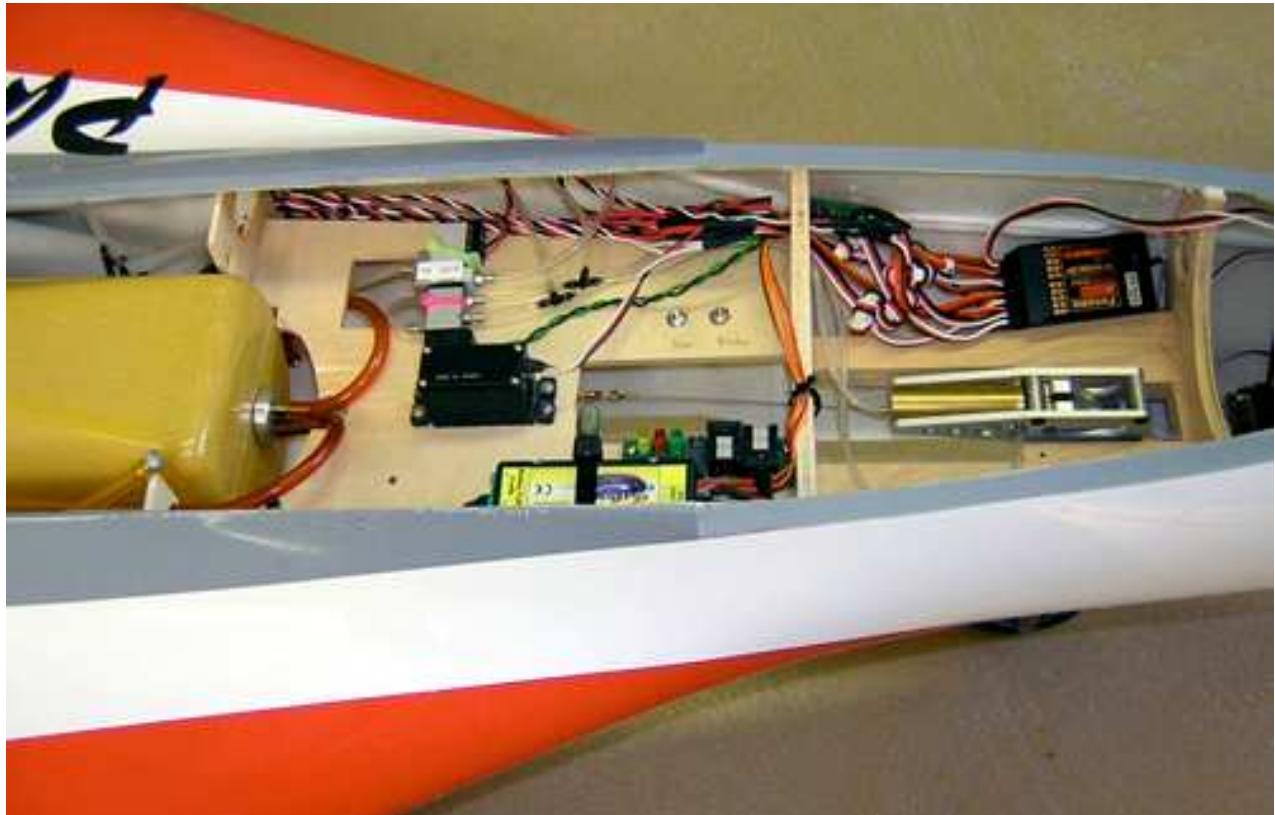

Recommended surface throws

Elevators

Up 18mm
Down 15mm
Exponential: 10

Ailerons

Up 15mm
Down 15mm
Exponential: 10

Rudder

15 mm left and 15 mm right
Exponential: 10

Flaps

25 mm down with also mix 2 mm up elevator for pitch down moment
70 mm down with also mix 4 mm up elevator for pitch down moment

All measured in the widest part of the surface
Exponential is not mandatory but improves the flight

Center of gravity

You normally need a 1700 Mah battery + ECU battery to have a correct Centre of Gravity.

Note : balance the model with the gear down and the tanks empty.

The center of gravity (CG) must be located at 128mm rear of the wing leading edge (wing root)

You must check it before the first flight, to do this with the aircraft in flight condition but without fuel lift the aircraft in this point, the aircraft must adopt a slightly nose down attitude. If it is horizontal or the tail drops move the batterie forward or add weight in the nose.

In other hand if the nose drops considerably add weight in the tail.

This CG position is the forward position. You can put it backward of 5 mm without trouble

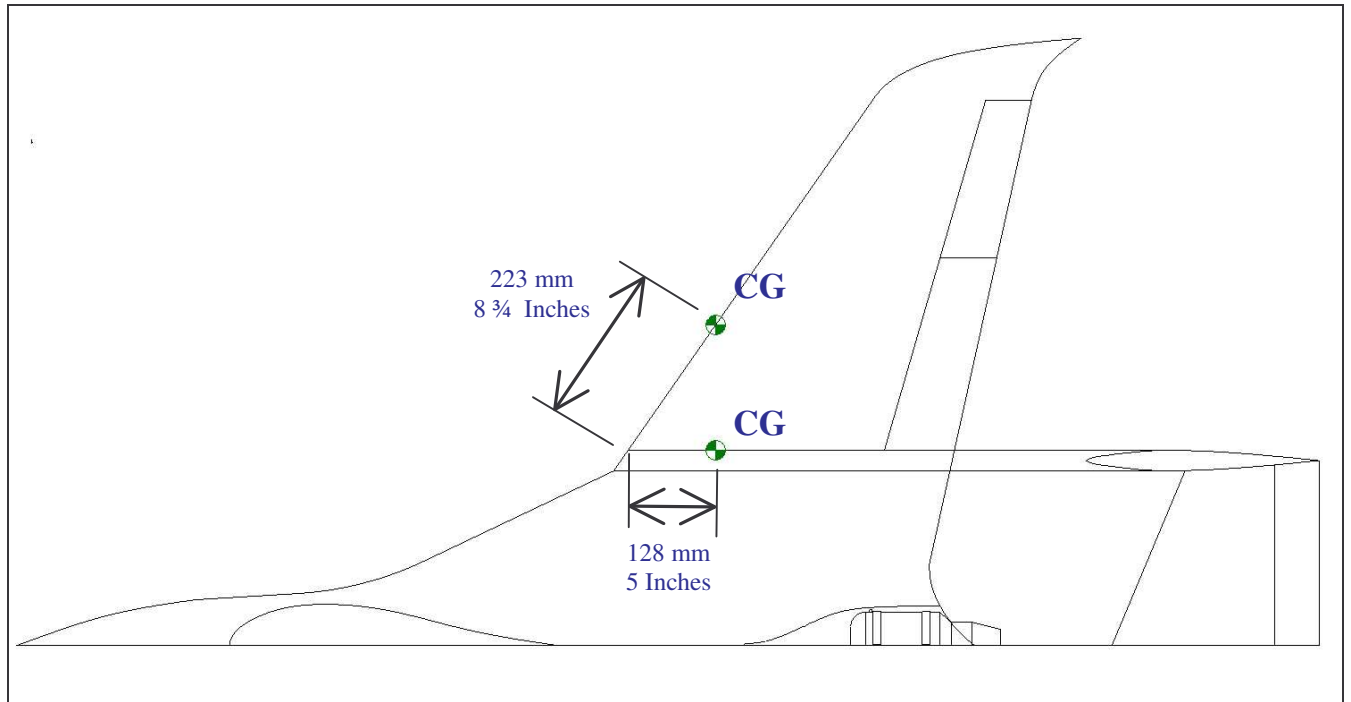

Total weight

The total weight of the *Phoenix* is 7.5 kg tanks empty.

Important note : Pay very careful attention to structural integrity. This jet can reach speeds of over 400 KPH - 250 MPH. It is your responsibility to operate it safely.

Specifications may change without notice.

Nota 1 : **Oleo legs :**

If you use the front oleo leg made by Eurokit in Italy, we strongly recommend to drill a 4 mm hole (40 mm long) through the fork and to glue a piano wire inside it to reinforce the aluminium casting

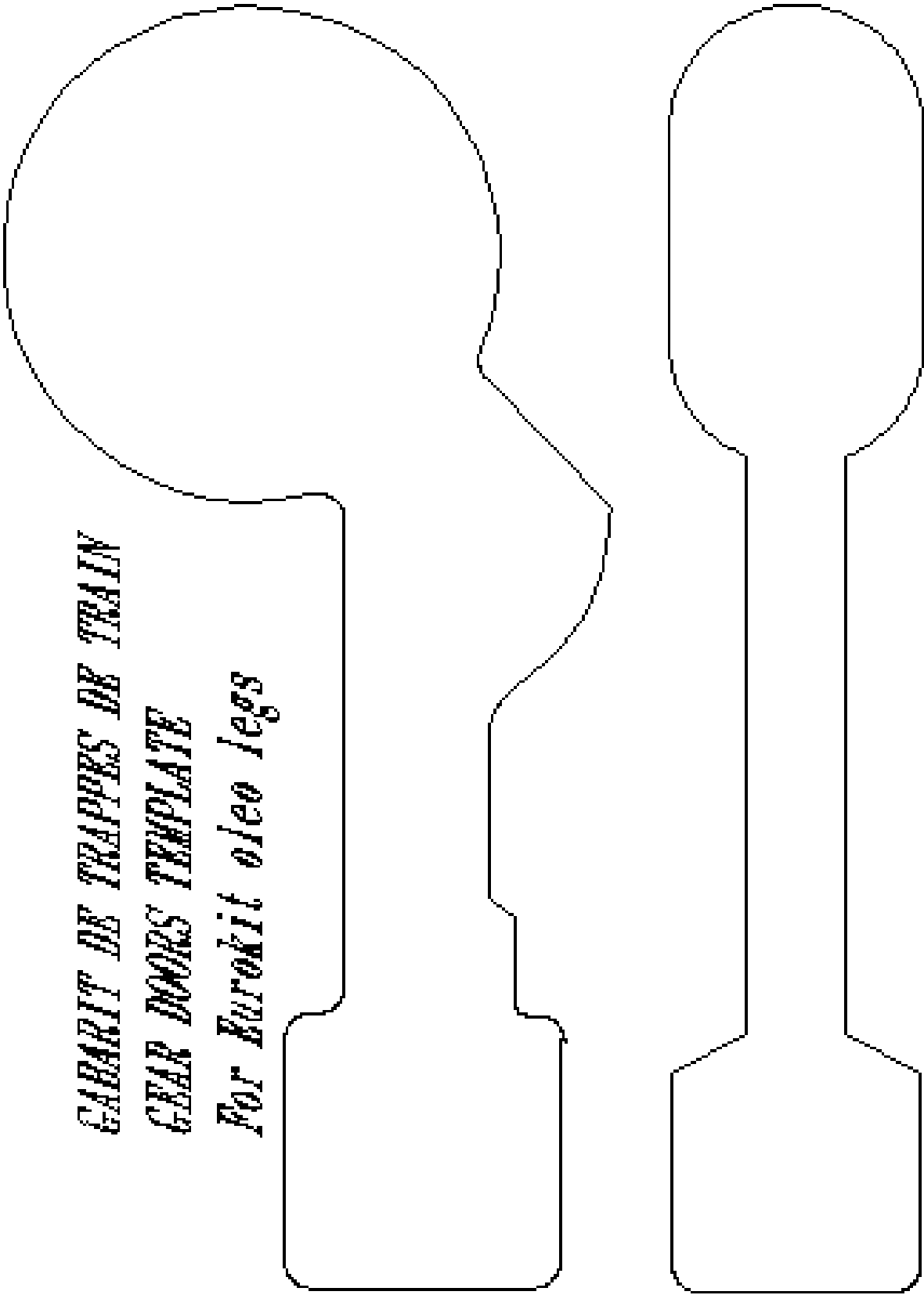

CABRIT DE TRAPPES DE TRAIN
GEAR DOORS TEMPLATE
For Eurokit oleo legs

*Gabarit de trappe de train
Gear door template
for behotec gear*

