



Snap-Stand Assembly manual

Please read this manual carefully till the very end BEFORE you start assembly!

We guarantee that this stand can safely bear the weight up to 60 pounds (30 kg) if assembled and used accordingly this manual.

What you will find in the box.

- | | |
|---|-------------------------------------|
| 1. Slotted Strut – 2 pcs. | 13. Foam tube – 2 pcs. |
| 2. Strut – 2 pcs. | 14. Bolt ¼"-2" – 6 pcs. |
| 3. Brace 482 mm (19") long – 2 pcs. | 15. Bolt ¼"-2 ½" – 2 pcs. |
| 4. Brace 440 mm (17 5/16") long – 2 pcs. | 16. Bolt ¼"-3" – 2 pcs. |
| 5. Brace 514 mm (20 1/4") long – 1 pcs. | 17. Wood Screw #8-2" – 12 pcs. |
| 6. Plate left – 2 pcs. | 18. Ny-Lock Nut ¼" – 8 pcs. |
| 7. Plate right – 2 pcs. | 19. Washer ¼" – 16 pcs. |
| 8. Cross-Bar - 2 pcs. | 20. Four-Wing Nut (male) – 4 pcs. |
| 9. Aluminum Tube – 2 pcs. | 21. Four-Wing Nut (female) – 2 pcs. |
| 10. Strap (short) with clasp – 2 pcs. | 22. Split-Pin – 4 pcs. |
| 11. Strap (long) – 2 pcs. | 23. Flanged Insert-Nut - 8 pcs. |
| 12. Brace 472 mm (18 9/16") long – 1 pcs. | 24. Assembly manual |

Tools and materials you will need to assemble the Snap-Stand:

Screwdriver Square #2 (red)
Hammer
Wrench 11 mm
Hex-screw driver 6 mm
Drilling machine
Drill bit 3 mm diameter (1/8")
Pliers

Glue - any carpenter wood glue for outdoor use or any epoxy-based glue - both will work well. Not supplied.

Step 1 - Assembling of rotary brackets.

Stand has two rotary brackets – large and small. **See picture 2.**

These brackets have two positions – working position and storage position. In working position it bear the weight of the model you place on the stand. In this position each bracket must be secured on place with four-wing nuts (male). When these nuts released, brackets could be laid down for storage or transportation.

For large rotary bracket you'll need one left (6) and one right plate (7) and one brace 514 mm (20 ¼") long (5).

For smaller rotary bracket you'll need one left (6) and one right plate (7) and one brace 472 mm (18 9/16") long (12).

Insert brace into the rabbets and drill 3mm diameter holes 40 mm deep in the brace ends through predrilled holes in the plates. Apply glue on the joint. Insert brace into the rabbets on the plates and tighten the screws (17).

Insert aluminum tube (9) inside the 12.7 mm diameter hole temporary. Put assembled brackets on flat surface. Make sure that whole structure is straight and square. Let the glue dry.

Outside dimension of small bracket is 500 mm (19 11/16"). Outside dimension of large bracket is 542 mm (21 3/8"). Tolerance is plus-minus 1-mm. Screw flanged insert nuts (23) in the holes 8 mm diameter. Rotary brackets assembled.

Step 2 – Assembling of the frames.

There are two frames – large and small. **See picture 3.**

For assembly of the large frame you'll need two slotted struts (1) and two braces 482 mm (19") long (3).

For assembly of the smaller frame you'll need two struts (2) and two braces 440 mm (17 5/16") long (4).

Insert braces into the rabbets and drill holes 3mm diameter and 40 mm deep in the brace ends through predrilled holes in the struts. Apply glue on the joint. Insert brace into the rabbets on the struts and tighten the screws.



Snap-Stand Assembly manual

Put frames on flat surface. Make sure that whole structure is straight and square. Let the glue dry. Screw in flanged insert nuts (23).

Outside dimension of small frame is 458 mm (18 1/16"). Outside dimension of large frame is 500 mm (19 11/16"). Tolerance is plus-minus 1 mm. The length of both frames is the same 900 mm (35 1/2"). Stand is ready for final assembly.

Step 3 - Final Assembly

Insert small frame inside of large frame. Make sure that holes in the frames concur. Insert bolts (14) 2" long into the holes 6.4 mm (1/4") diameter. Place one washer (19) between the frames and one washer under the Ny-Lock Nut (18) according picture 4. Tighten the nuts tight. Then loosen it slightly just enough to let joint move freely.

Install crossbars (8) at both sides of the stand, according **picture 4**. Use bolts (16) 3" long at the bulge end of the cross-bar. Place one washer under the Ny-Lock Nut (18). Tighten the nuts tight. Then loosen it slightly just enough to let joint move freely.

Insert 2 1/2" bolts (15) into the hole at the thin end of the crossbar. Make sure this bolt goes through the slot in the frame at the same time. Place one washer (19) under Four-Wing Nut (21) according the sketch. Pull apart the legs of the stand and place it on the ground. Tighten four-wing nuts. Make sure that the bevels at the bottom of both frames are facing the ground (**see pictures 1 and 6**).

Install both rotary brackets on place according **picture 5**. Insert the bolts (14) 2' long into the openings. Place one washer (19) between the frames and plate and one washer under the Ny-Lock Nut according picture 5. Tighten the nuts tight. Then loosen it slightly just enough to let joint move freely.

Screw four-wing nuts (male) (20) in. Make sure threaded ends go into the flanged nuts on the frames to fix rotary bracket in the upper position. Tighten the nuts by hand. There is no need to tighten it too tight.

To release the bracket and let it go down for transportation or storage unscrew wing nuts just enough to let threaded ends out of the frame flanged insert nuts. **See picture 7**.

Put short (11) and long (10) parts of the nylon strap at the ends of aluminum tubes (9) according picture 5 and 6. Join it with the clasp. Using this clasp you can adjust needful length of the strap according the size of the model, you are going to place on the stand.

Using pliers insert the split-pins (22) in the opening at each end of aluminum tube. These pins prevent the straps from sliding off. The tube fits tight in the plate's holes when it's brand new, but it's normal when it moves freely.

Some recommendations

Before you tighten the nuts insert the bolts into the holes and tap it with the hammer to make square hollows in wooden parts. It prevents rotating of the bolts when you tighten the nuts.

After all parts glued together and final assembly finished, disassemble Stand. Remove all stickers, nuts, bolts and washers. After that we recommend to put at least two layers of oil, varnish or lacquer on all wooden parts. Use any proper brand of mentioned products apt to kind of fuel you use and your own taste. Sand covered parts between the layers. We recommend put foam tubes (13) on the top of aluminum tubes to protect accidental damage of your model.

We hope our Snap-Stand will help you to keep you models served well and safely as they deserve it at the field or in your workshop during a years and it let you enjoy this beautiful hobby even more.

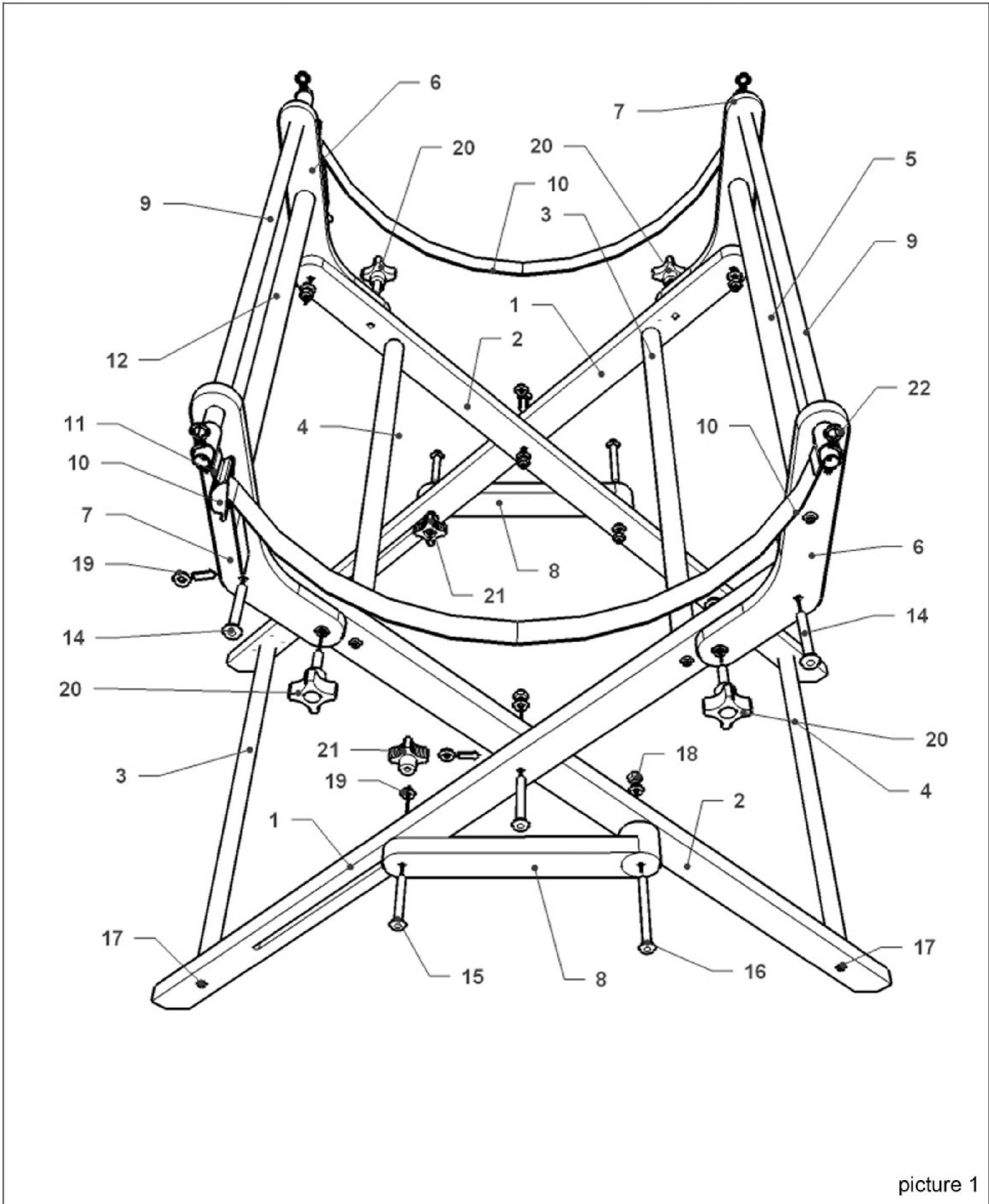

picture 1

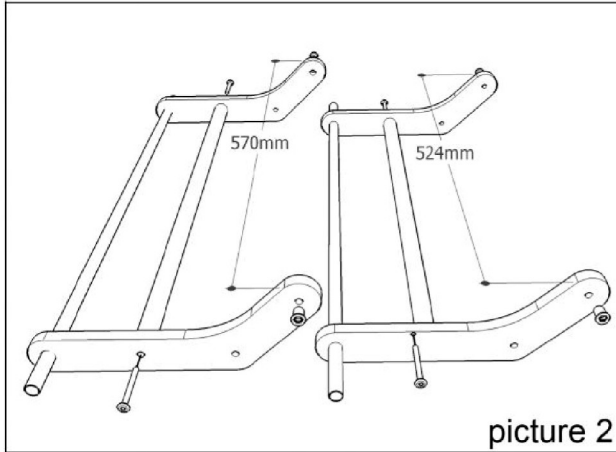

picture 2

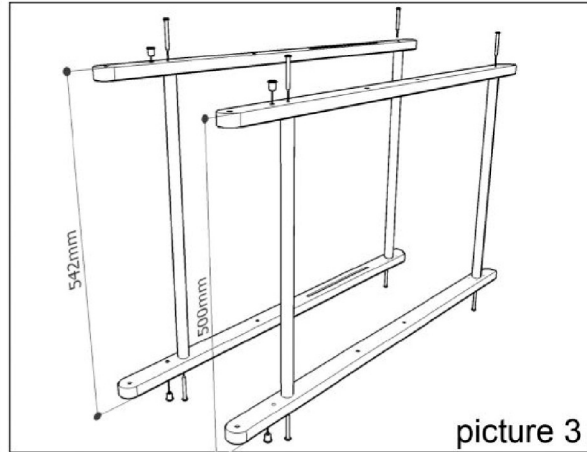

picture 3

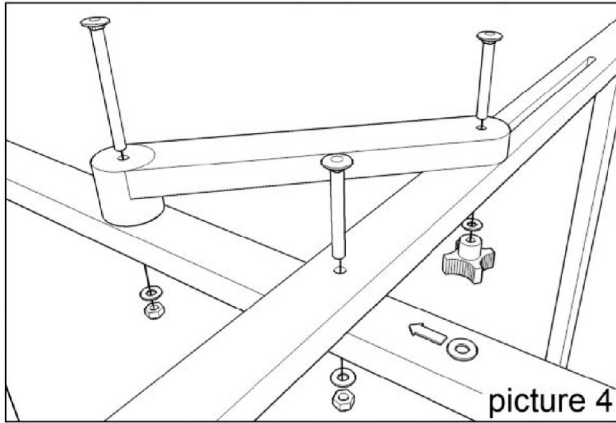

picture 4

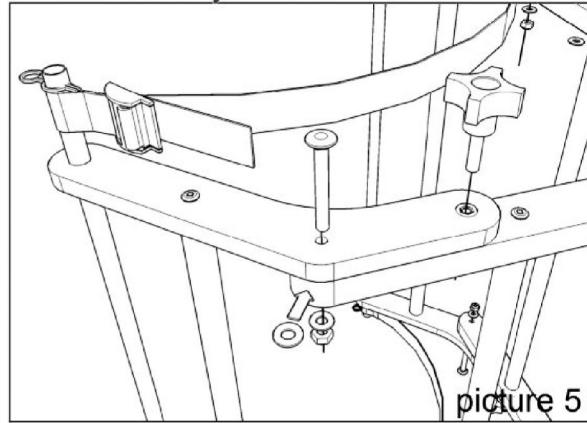

picture 5

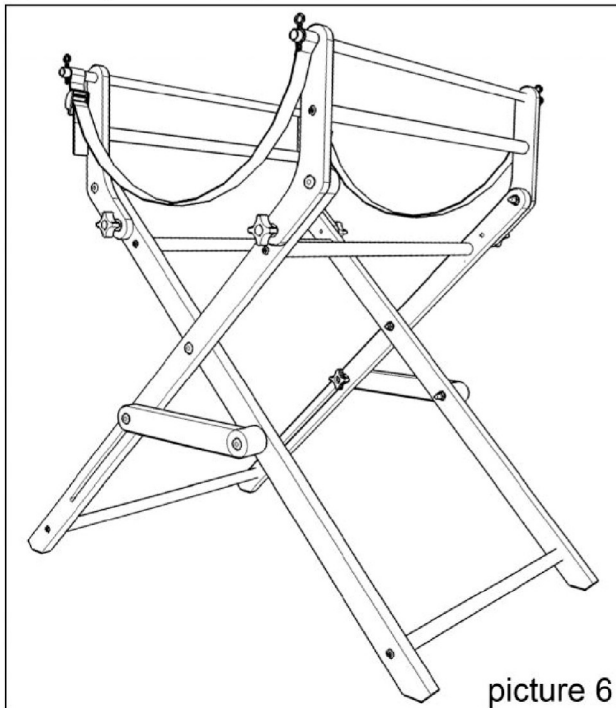

picture 6

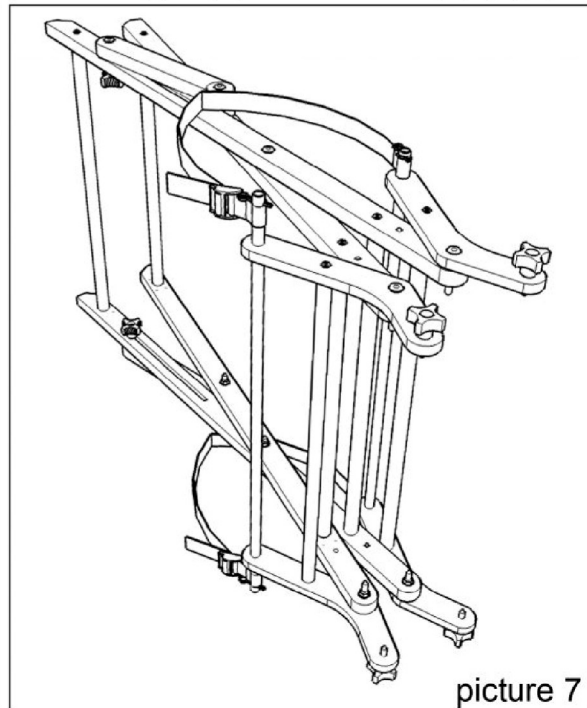

picture 7